

# **Una passeggiata per la Piazza San Marco**

per nove clarinetti

Mike Solomon

“L'unica soluzione che abbiamo per eliminare la questione piccioni in Piazza San Marco è quella di avere un decreto ministeriale che allontani i venditori di grano, principale causa della presenza dei volatili, dalla zona in questione. Noi, come amministrazione comunale, purtroppo non possiamo fare nulla.” – Massimo Cacciari, il Sindaco di Venezia (2007)

“The only solution that we have found to eliminating the pigeons from the Piazza San Marco is the issuance of a municipal decree that bans vendors of birdfeed, who principally cater to tourists, from the zone in question. Unfortunately, we as an administration cannot do anything else.” – Massimo Cacciari, Mayor of Venice (2007)

**The ensemble should arrange itself according to the diagram below.**

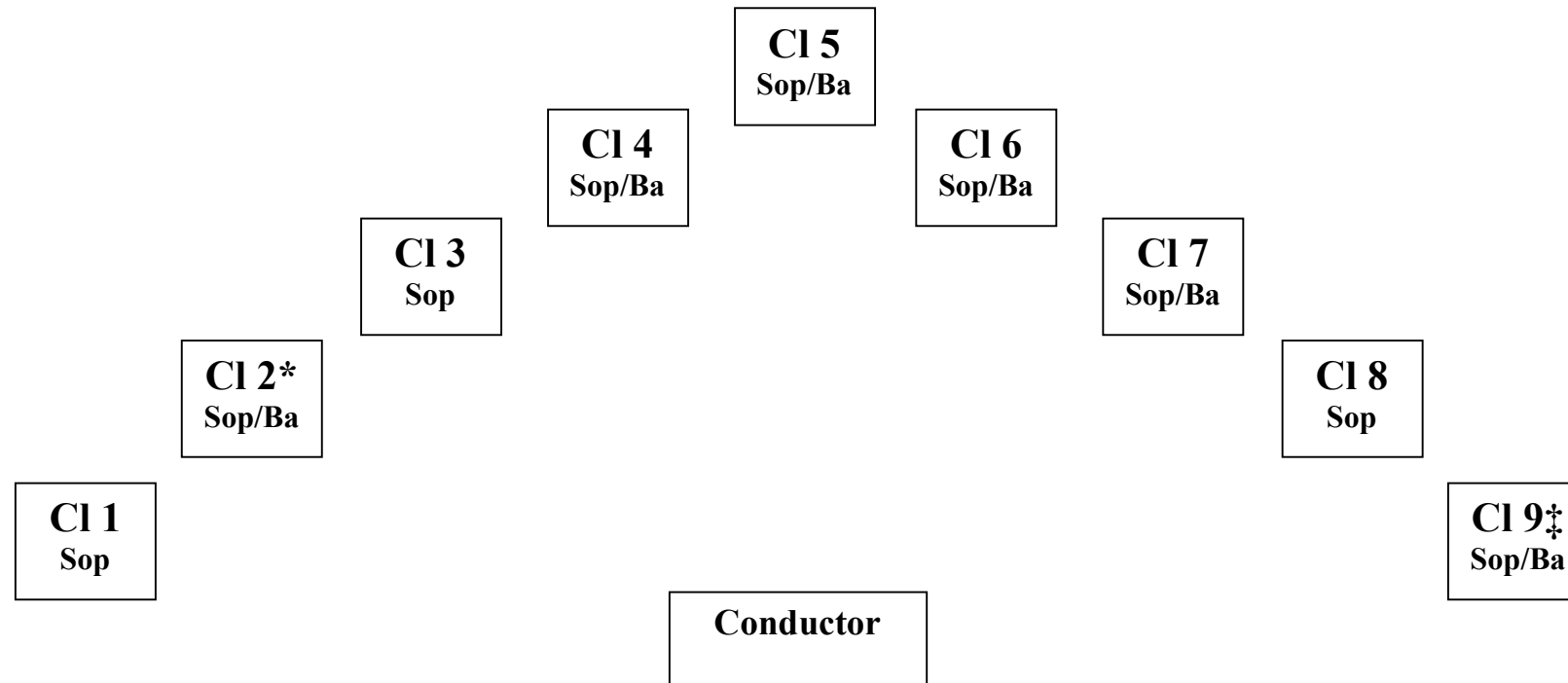

The spacialization of the work is of the utmost importance. Every interpretive decision must take this parameter into consideration!

Ogni suonatore deve potere fare vibrati linguali.

\* Must be able to sustain notes via circular breathing.  
‡ Must be able to make gnarly overtones on the bass.  
Every player must be able to flutter tongue.

## Preface and lexicon of Italian terms in English

### Notes:

The fingerings for the timbral trills are written on the page during which the trill begins. Each fingering is written only once.

In order to best execute quick changes between the soprano and bass clarinet, cradle the bass in your arm and, at the time of the change, drop the soprano and let it dangle on its string momentarily to execute the bass note. Ample time is given after all such changes so that the clarinetists may properly arrange their instruments and recalibrate their inner peace.

While playing the bass clarinet, all of the “squawks” should be made with the overtones of a low bass note.

### Lexicon:

Phrases are presented in the order in which they appear in the score. Standard Italian nomenclature is not translated.

#### Italiano

*Una passeggiata per la Piazza San Marco*

*Con gusto sperimentale*

*come l'emissione stocastica di neutroni di una particella radioattiva*

*selvaggio e spericolato*

*tr tim.*

*beccando*

*piuttosto libero con il ritmico*

#### English

A stroll through Saint Mark's Square (Venice, Italy)

With experimental gusto

like the stochastic emission of neutrons from a radioactive particle

wild and savage

timbral trill

pecking

rather free with the rhythm

**Avviso!** Il secondo, quarto e quinto clarinetto devono fare un cambiamento **MOLTO RAPIDO** del soprano al basso dentro la ventunesima e la ventiduesima misura rispettivamente.

*alternare tra i tasti grigi per fare il trillo timbrico sul [nota]*

*il richiamo di un gabbiano*

*non si senta obbligato a seguire strettamente il tempo*

*come una anatra ferita*

*quasi strisciando*

*piegare l'intonazione e il volume come i giri di un motore*

*congelato nel tempo*

*quasi come una melodia*

*scintilla*

**NB:** I punti d'entrata e i tempi per le scale cromatiche sono approssimativi.

*un poco fuori tempo, quasi rit.*

*più e più lento con il trillo*

*solo l'aria*

*appena prima della battuta*

*adesso l'altezza*

*un gracchiare*

*non schierando con il [numero] clarinetto!!! fuori fase!!!*

*attualizzare il gesto, non le note*

*quantità approssimativa di note*

*schifoso, disgustoso, osceno, come se l'anatra morisse*

**Warning!** The second, fourth, and fifth clarinet must make a **VERY FAST** change from soprano to bass in the twenty-first and twenty-second measure respectively.

alternate between the grey keys in order to execute the timbral trill on [note]

the cry of a gull

do not feel obliged to strictly follow the tempo

like a wild duck

almost crawling

fluctuate the intonation and the volume like the revving of a motor

frozen in time

almost like a melody

shimmering, scintillating

**NB:** The entrance points and the tempi for the chromatic scales are approximate.

a little out of time, almost slowing down

slower and slower with the trill

only the air

just before the beat

now the pitch

a caw

do not line up with the [number] clarinet!!! out of phase!!!

focus on the gesture, not the notes

approximate quantity of notes

foul, disgusting, obscene, as if the duck were dying

# Una passeggiata per la Piazza San Marco

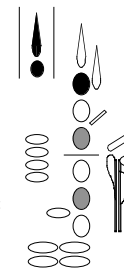

Mike Solomon

Con gusto sperimentale ♩ = ca. 64

Audacemente e con forza ♩ = ca. 82

alternare tra i tasti grigi per fare il trillo timbrico sul la

Clarinetto 1mo Soprano in Si $\flat$  \* \*  $\hat{}$

Clarinetto 2do Soprano in Si $\flat$  \*  $mp$   $mp$  *selvaggio e spericolato tr tim*  $f$  *selvaggio e spericolato tr tim*

Clarinetto 3zo Soprano in Si $\flat$   $f$

Clarinetto 4to Soprano in Si $\flat$  \*  $mp$   $mp$

Clarinetto 5to Soprano in Si $\flat$   $mp$   $mp$  *beccando piuttosto libero con il ritmico*  $mp$   $mf$   $6$

Clarinetto 6to Soprano in Si $\flat$  *vib. ling.*  $mf$   $mf$   $3$   $f$   $5$   $5$   $mf$   $3$

Clarinetto 7mo Soprano in Si $\flat$  \* \*  $\hat{}$   $p$   $5$   $5$  *il richiamo di un gabbiano*  $mf$   $mf$  *sim.*

Clarinetto 8vo Soprano in Si $\flat$   $mp$   $mp$   $mf$   $mf$

Clarinetto 9no Basso in Si $\flat$   $\hat{}$

\* come l'emissione stocastica di neutroni di una particella radioattiva

**Avviso!** Il terzo, quarto e quinto clarinetto devono fare un cambiamento MOLTO RAPIDO del soprano al basso dentro la ventunesima e la ventiduesima misura rispettivamente.

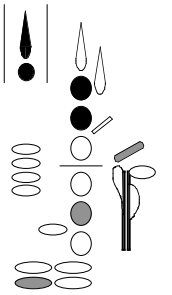

alternare tra i tasti grigi per fare il trillo timbrico sul sol

14

*vib. ling.* *beccando piuttosto libero con il ritmico*

Cl. 1mo

*mp* *tr tim* *mf* *p* *mf* *mf* *p* *mf*

Cl. 2do

*tr tim*

Cl. 3zo

14 *beccando piuttosto libero con il ritmico*

*p* *mf* *mf* *sim.* *p* *mf* *tr tim*

Cl. 4to

*beccando* *mf* *mf* *f* *non si senta obbligato a seguire strettamente il tempo*

Cl. 5to

*beccando piuttosto libero con il ritmico* *p* *mf* *mf* *mf* *mf*

Cl. 6to

*mp* *mf* *p* *mf* *mp* *mp* *f* *non si senta obbligato a seguire strettamente il tempo*

*vib. ling.* *mp* *mf* *p* *mf* *mp* *mp* *f*

Cl. 7mo

*mp* *sim.* *p* *f* *sim.* *mf*

Cl. 8vo

*mf* *mp* *mf*

Cl. 9no

14

alternare tra i tasti grigi per fare il trillo timbrico sul fa

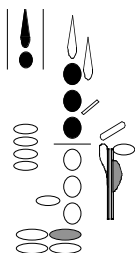

*il richiamo di un gabbiano* **moltissimo rit!** *quasi strisciando* **Tempo I, non rigidamente** ♩ = ca. 64 *poco accel.* *quasi come una melodia* **rit.**

**Soprano in Si $\flat$**

**Basso in Si $\flat$**  *vib. ling. piegare l'intonazione e il volume come i giri di un motore*

*tr tim.*

**Basso in Si $\flat$**  *vib. ling.*

**Soprano in Si $\flat$**

*multifonica come una anatra ferita*

**ff** † *congelato nel tempo*

Cl. 1mo  
Cl. 2do  
Cl. 3zo  
Cl. 4to  
Cl. 5to  
Cl. 6to  
Cl. 7mo  
Cl. 8vo  
Cl. 9no



Una passeggiata per la Piazza San Marco

Allegro festevole ♩ = ca. 85

Cl. 1mo *mp*

Cl. 2do *mp*

Cl. 3zo *con moto*

Cl. 4to *mp* *p* *scintilla* *mf* *Basso in Si<sup>b</sup> non strettamente in tempo*

Cl. 5to *mf*

Cl. 6to *con moto*

Cl. 7mo *con moto* *mf* *mp*

Cl. 8vo *con moto* *mf* *mp*

Cl. 9no *mf* *vib. ling.* *p*

*a tempo* *stringendo*

Moderato, non strettamente in tempo ♩ = ca. 56

The musical score is arranged in nine staves, labeled Cl. 1mo through Cl. 9no, and a Soprano in Si $\flat$ . The music is in 4/4 time and begins at measure 40. The first four staves (Cl. 1mo to Cl. 4to) feature melodic lines with various articulations and dynamics. Cl. 1mo and Cl. 2do have slurs and accents. Cl. 3zo has a triplet and a slur. Cl. 4to has a triplet and a slur. The Soprano part enters in measure 40 with a slur and a vibrato marking. The remaining five staves (Cl. 5to to Cl. 9no) feature dense chromatic textures with slurs and accents. Cl. 5to and Cl. 6to have slurs and accents. Cl. 7mo has a slur and an accent. Cl. 8vo has a slur and an accent. Cl. 9no has a triplet and a slur. Dynamics include *mp*, *legato*, *sim.*, and *mf*. The score is written in a single system with a double bar line in the middle.

NB: I punti d'entrata e i tempi per le scale cromatiche sono approssimativi.







Una passeggiata per la Piazza San Marco

48

Cl. 1mo *mp*

Cl. 2do *mp* *sim.* 3 3

Cl. 3zo *mp* *sim.* *p*

Cl. 4to

Cl. 5to *mp* *sim.* *mp* *p* *un poco fuori tempo, quasi rit.*

Cl. 6to *mp* *sim.* *mp* *non strettamente in tempo*

Cl. 7mo *mp*

Cl. 8vo \* 5

Cl. 9no \* 48

Detailed description: This page of a musical score contains nine staves for clarinets, numbered Cl. 1mo to Cl. 9no. The score is divided into two systems by a double bar line. The first system covers measures 48 to 96. The notation includes various rhythmic patterns, primarily eighth and sixteenth notes, often beamed together. Dynamic markings such as *mp* (mezzo-piano) and *p* (piano) are used throughout. Performance instructions include *sim.* (sforzando), *un poco fuori tempo, quasi rit.* (slightly out of tempo, almost ritardando), and *non strettamente in tempo* (not strictly in tempo). Fingerings are indicated by numbers 1-5, and a specific fingering for a fifth finger is marked with an asterisk (\*). The key signature has one sharp (F#) and the time signature is 3/4. The score concludes with a final measure in the second system.







Una passeggiata per la Piazza San Marco

*il richiamo antifonico di un gabbiano* *poco rit.* *a tempo* *il richiamo di un gabbiano* *un poco più mosso*

Cl. 1mo *mf* *mf*

Cl. 2do *ppp* *mf* *mf*

Cl. 3zo *mp* *mf*<sup>3</sup>

Cl. 4to *mf*

Cl. 5to *p* *un gracchiare* *mf*<sup>5</sup> *mf*<sup>5</sup>

Cl. 6to *Basso in Si $\flat$*  *mf*<sup>5</sup> *mf*<sup>5</sup> *mf*<sup>5</sup> *mf*<sup>3</sup>

Cl. 7mo

Cl. 8vo

Cl. 9no *il richiamo antifonico di un gabbiano* *mf* *mf* *mf*



*poco stringendo*

Cl. 1mo *mf*

Cl. 2do *Basso in Si* *f*

Cl. 3zo *mf* *mf* *mf*

Cl. 4to *mf* *mf* *mf* *mf*

Cl. 5to *tr tim*

Cl. 6to *mf* *mf* *mf* *mf* *mf* *mf* *mf*

Cl. 7mo *tr tim*

Cl. 8vo *mf* *pp*

Cl. 9no *mp*





**Allegro festiva** ♩ = ca. 85

*rit.*

106

Cl. 1mo

Cl. 2do

Cl. 3zo

Cl. 4to

Cl. 5to

Cl. 6to

Cl. 7mo

Cl. 8vo

Cl. 9no

*mf*

Soprano in Si $\flat$

*mf*

Soprano in Si $\flat$

\*

*mp*

*mp*

106

Detailed description: This is a page of a musical score for nine clarinets and two sopranos. The score is arranged in a grand staff with nine staves for clarinets (Cl. 1mo to Cl. 9no) and two staves for sopranos (Soprano in Si $\flat$ ). The music is in 3/4 time and begins at measure 106. The tempo is marked 'Allegro festiva' with a quarter note equal to approximately 85 beats per minute. A 'rit.' (ritardando) marking is present above the first staff. The first staff (Cl. 1mo) has a treble clef and contains a melodic line starting in measure 5. The second staff (Cl. 2do) has a bass clef and contains a melodic line starting in measure 5, with triplets indicated by '3' and horizontal lines. The third staff (Cl. 3zo) has a treble clef and contains a melodic line starting in measure 5, also with triplets. The fourth staff (Cl. 4to) has a bass clef and contains a melodic line starting in measure 5, with an asterisk (\*) above a note in measure 6. The fifth staff (Cl. 5to) has a bass clef and contains a melodic line starting in measure 5. The sixth staff (Cl. 6to) has a bass clef and is mostly empty. The seventh staff (Cl. 7mo) has a bass clef and is mostly empty. The eighth staff (Cl. 8vo) has a treble clef and is mostly empty. The ninth staff (Cl. 9no) has a treble clef and contains a melodic line starting in measure 5. Dynamics include *mf* (mezzo-forte) and *mp* (mezzo-piano). The score is divided into measures by vertical bar lines.